

Portable Bulk Tanks

A Re-usable Alternative to Barrel Packaging

Composition: Portable Bulk Tanks are 475 gallon reusable containers designed for material transport and product delivery. Portable Bulk Tanks are constructed from 10 gauge carbon steel and are built according to US DOT (Department of Transportation) and UN (United Nations) performance packaging standards.

Basic Uses: Portable Bulk Tanks are used to deliver bulk quantities of BURmastic to the jobsite. Once delivered, a standard roofing pump is connected to the Portable Bulk Tank to pump the product directly to the roof. When the tank is empty, it is shipped back to Tremco for refilling and reuse. Portable Bulk Tanks are ideal for use in areas where empty barrel disposal is a problem.

Limitations:

- Portable Bulk Tanks which contain product must not be stored at temperatures below 45°F (7°C).
- Keep Portable Bulk Tanks on level ground. Not intended for use or storage on roof, plaza, or parking garage decks.

Warning:

- The air vent on top of each Portable Bulk Tank must be fully opened when removing material or collapse of tank may result. Air vent must be closed at all other times.

Capacity: 475 gallons (1,798 L)

INSTRUCTIONS FOR USE:

1. Unload Portable Bulk Tanks from delivery truck. Use proper material handling equipment, such as a crane or forklift truck. Equipment must be rated to handle a minimum 6,000 lbs (2,722 kg).
2. Place Portable Bulk Tanks on a solid, level surface, away from excessive heat, sparks or open flame. Protect blacktop surface from damage caused by heavy loads.
3. Construct adaptor fittings so the roof pump will connect to the quick connect fitting on the bottom drain valve of the Portable Bulk Tank.
 - Use 3" (76 mm) I.D. (inside diameter) adapter fittings.
 - Keep total adapter length as short as possible, less than 30" (762 mm).
 - Most pump manufacturers require the pumps be vertical to operate properly.
 - See drawing on next page for further details.
4. Make sure bottom drain valve on the Portable Bulk Tank is in the off/closed position. Carefully disconnect dust cap cover from bottom drain valve.
5. Connect roof pump to Portable Bulk Tank, using properly matched adapter fittings. Secure quick connect with rubber straps to prevent accidental disconnect due to pump movement.
6. Open 3" I.D. air vent on top of tank prior to starting pump. **Warning: Air vent must be fully opened when removing material or collapse of tank may result.**
7. Open bottom drain valve to begin flow of material from the tank to the roof pump.

Product Advantages	
Features	Benefits
Re-usable	<ul style="list-style-type: none"> • Environmentally responsible • Eliminates barrel disposal
Bulk quantity	<ul style="list-style-type: none"> • More efficient job production
UN/DOT Approved design	<ul style="list-style-type: none"> • Certified for safe transport of product
Cone bottom design	<ul style="list-style-type: none"> • Minimizes loss of product which cannot be recovered
10 gauge steel construction	<ul style="list-style-type: none"> • Heavy duty • Withstands rigors of jobsite handling
Forklift channels & lifting lugs	<ul style="list-style-type: none"> • Movable by crane or forklift truck
3" Quick connect adapter	<ul style="list-style-type: none"> • Easy hookup to pump • Allows fast move to next tank
Lockable dust cap cover	<ul style="list-style-type: none"> • Keeps drain valve clean during shipping/storage • Can be padlocked for added security



Roofing & Weatherproofing Peace of Mind™

8. Turn on roof pump to begin spray application.
9. When tank is empty, turn off roof pump. Close air vent on the top of the Portable Bulk Tank.
10. Close bottom drain valve and disconnect roof pump adapter fittings from the Portable Bulk Tank. Reconnect dust cap cover on bottom drain valve.

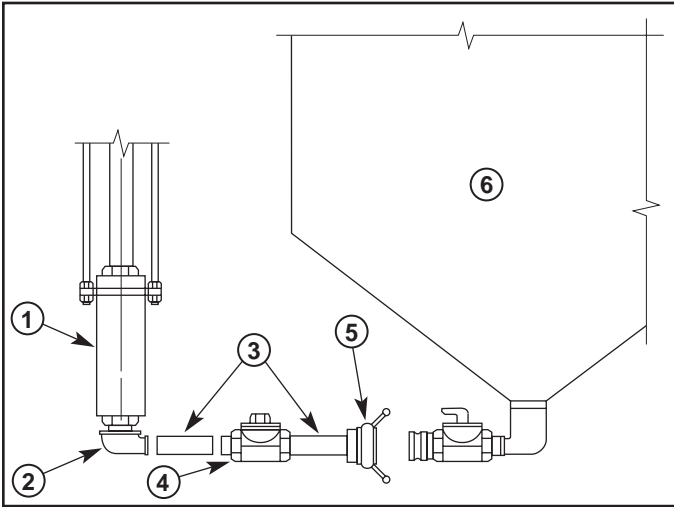

- Key:**
1. Standard Roofing Pump
 2. Threaded Adaptor/Pipe Elbow
 3. 3" (76mm) I.D. Reinforced Petroleum Transfer Hose
 4. Clean Out Fitting (Optional)
 5. 3" (76mm) I.D. Quick Connect Coupler
 6. Portable Bulk Tank

Precautions: Users must read container labels and Material Safety Data Sheets for health and safety precautions prior to use.

The contractor is responsible for the safe movement, storage, and security of each Portable Bulk Tank. The contractor must maintain, convey, use, and operate each Portable Bulk Tank in compliance with all applicable laws and regulations.

Availability and Cost: Contact your local Tremco Roofing Representative for pricing and availability. For the name and number of your Representative, call the Roofing Division at 216/292-5000.

Maintenance: Your local Tremco Roofing Representative can provide you with effective maintenance procedures which may vary, depending upon specific conditions. Periodic inspections, early repairs and preventative maintenance are all part of a sound roof program.

Guarantee/Warranty: Tremco, Inc. warrants its roofing products to be free of defects and to meet published physical properties when tested according to ASTM and Tremco standards. Under this warranty, any product that is proved to be defective when applied in accordance with our written instructions, and in applications recommended by Tremco as suitable for this product will be replaced with like product at no charge. THIS IS BUYERS SOLE AND EXCLUSIVE REMEDY.

Tank Specifications

Portable Bulk Tanks

Capacity	475 gal (1,798 L)
Dimensions	42" X 48" (1.1 m X 1.2 m) base 86" (2.2 m) height
Weight (approximate)	4,800 lbs (2180 kg) full 850 lbs. (386 kg) empty

All claims concerning product defects must be made in writing within twelve (12) months of shipment. The absence of such claims in writing during this period will constitute a waiver of all claims with respect to such product. This warranty shall be IN LIEU OF any other warranty, express or implied, including but not limited to, any implied warranty of MERCHANTABILITY OR FITNESS FOR A PARTICULAR PURPOSE.

Technical Services: Your local Tremco Representative, working with the Technical Service Staff, can help analyze conditions and needs to develop recommendations for special applications. The services of the Tremco Research Center, which has earned a unique reputation in weatherproofing technology, complement and extend the services of the Tremco Technical Service staff.

Statement of Policy and Responsibility: Tremco takes responsibility for furnishing quality materials and for providing specifications and recommendations for their proper installation.

As neither Tremco itself nor its Representatives practice architecture or engineering, Tremco offers no opinion on, and expressly disclaims any responsibility for the soundness of any structure on which its products may be applied. If questions arise as to the soundness of a structure or its ability to support a planned installation properly, the Owner should obtain the opinion of competent structural engineers before proceeding. Tremco accepts no liability for any structural failure or for resultant damages, and no Tremco Representative is authorized to vary this disclaimer.

TREMCO

An RPM Company

3735 Green Road
Beachwood, OH 44122
216-292-5000

220 Wicksteed Ave
Toronto, ONT M4H 1G7
416-421-3300

R00 - 181 4/95
Printed in USA